

DRIVEWAY GRADES:

1" = 10'

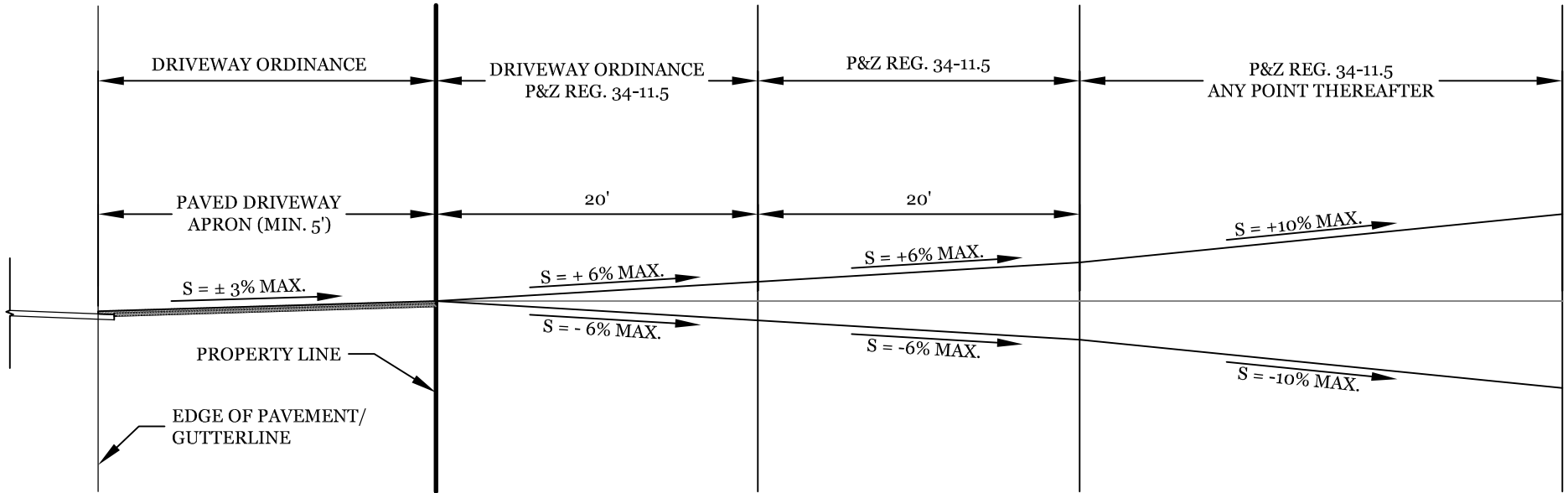

DRIVEWAY APRON CROSS SECTION:

1" = 2'

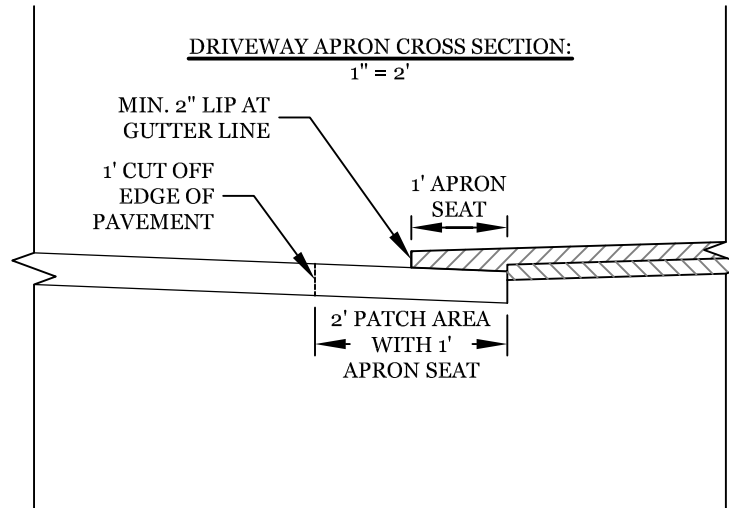

GENERAL NOTES:

1. CUT EXISTING PAVEMENT FROM EDGE WITH COMPRESSOR AND REMOVE PAVEMENT IN THIS AREA.
2. LAY 12" OF 1-1/2" PROCESS BASE FROM PROPERTY LINE TO GUTTER WITH 3% MAX. SLOPE FROM PROPERTY LINE TO GUTTER.
3. BLEND DRIVEWAY INSIDE PROPERTY LINE FROM EXISTING GROUND LEVEL TO PAVED SECTION TO PROVIDE VEHICLE ACCESS WITHOUT SCRAPING UNDERSIDE.
4. BLEND ANY EXISTING SIDEWALKS TO FINISHED GRADE OF DRIVEWAY.
5. SEE TOWN OF WESTPORT DRIVEWAY ORDINANCE AND PLANNING & ZONING REGULATION SEC. 34-11.5 :GRADES FOR MORE INFORMATION.

DRAWN BY	A. MATHARU	TITLE:		DESCRIPTION:	PREPARED BY:
DATUM	N/A	DRIVEWAYS: DETAILS & NOTES		MAXIMUM GRADES ALLOWED PER DRIVEWAY ORDINANCE AND P&Z REGULATIONS	TOWN OF WESTPORT ENGINEERING DIVISION 110 MYRTLE AVENUE WESTPORT, CT 06880
SCALE	AS NOTED				
DATE	07/18/2017				
REVISION	N/A				

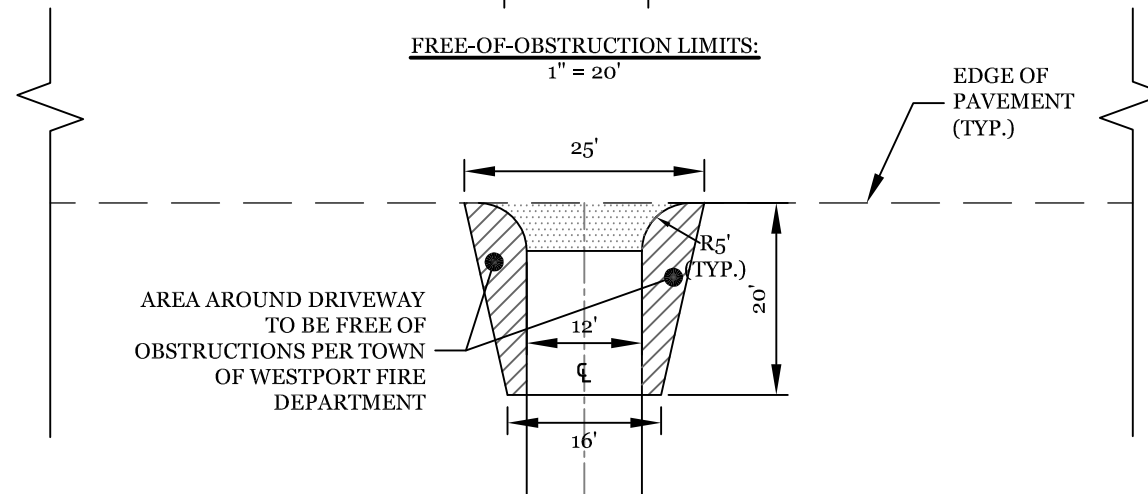
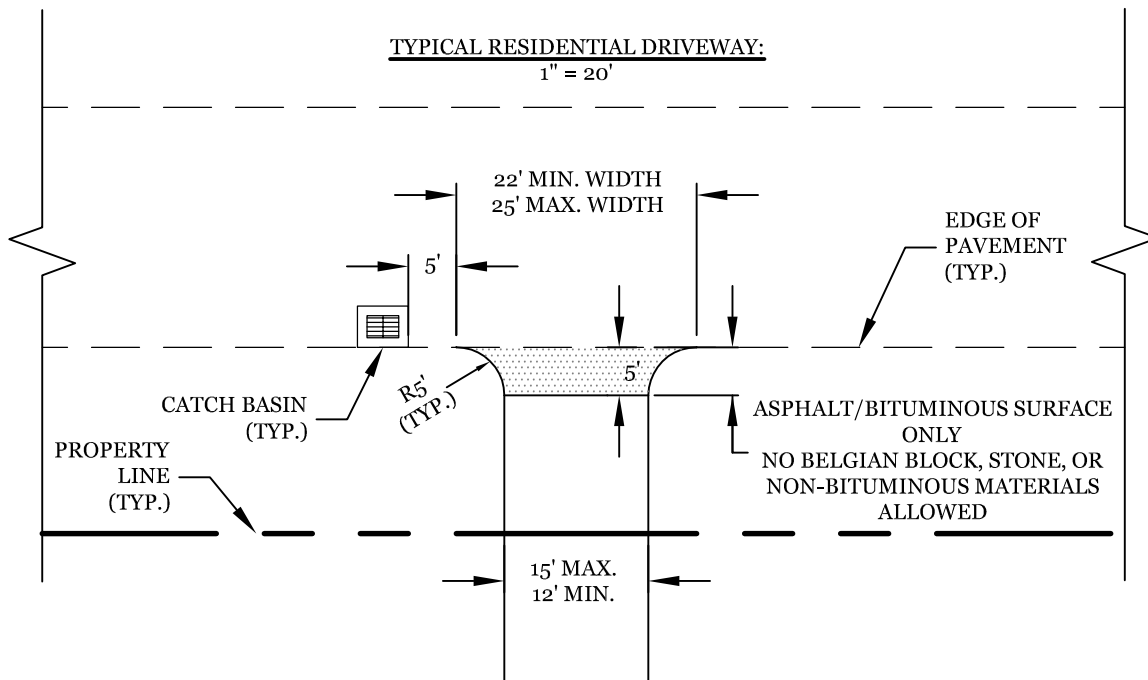

DRAWN BY	A. MATHARU	<u>TITLE:</u>		<u>DESCRIPTION:</u>	<u>PREPARED BY:</u>
DATUM	N/A	DRIVEWAYS: DETAILS & NOTES		MAXIMUM GRADES ALLOWED PER DRIVEWAY ORDINANCE AND P&Z REGULATIONS	TOWN OF WESTPORT ENGINEERING DIVISION 110 MYRTLE AVENUE WESTPORT, CT 06880
SCALE	AS NOTED				
DATE	07/18/2017				
REVISION	N/A				



# WESTPORT, CONNECTICUT

DEPARTMENT OF PUBLIC WORKS  
TOWN HALL, 110 MYRTLE AVE.  
WESTPORT, CONNECTICUT 06880  
(203) 341 1120

PERMIT #

PERMIT FEE \$50.00

## APPLICATION FOR DRIVEWAY PERMIT

**FOR PURPOSES OF:** (CHECK ONE)    ( ) RESIDENTIAL    ( ) COMMERCIAL

<b>LOCATION</b>	<b>ASSESSOR'S MAP #</b>	<b>TAX LOT #</b>
-----------------	-------------------------	------------------

### APPLICANT'S/ OWNER INFORMATION

APPLICANT / PROPERTY OWNER	PHONE #
MAILING ADDRESS	FAX #

### DRIVEWAY CONTRACTOR INFORMATION

CONTRACTOR	PHONE #
MAILING ADDRESS	FAX #

**"CALL BEFORE YOU DIG" NO.**

1. Driveway must conform to the requirements of the Town "Driveway Ordinance", copy given to the individual who obtains permit.
2. Applicant must submit a "PLOT PLAN", or a scaled drawing, showing the following items:
  - a.) Location and dimensions of the driveway in relation to the abutting property lines and street lines.
  - b.) Location of all applicable utilities, i.e. storm drainage (Town, State or private), utility poles, fire hydrants, transformers ...etc., that may be in conflict with the proposed driveway.
3. No decorative stone or stone like materials (i.e. Belgium Block, brick, concrete ...etc.) are to be placed within the Town's Right-of-Way without prior approval from the Town Engineering Dept, if an approval is granted the Applicant must execute a Hold-Harmless Agreement and file it on the Land Records in the Town Clerk's office prior to the commencement of construction.
4. Applicant must obtain a permit from the Town of Westport Tree Warden prior to the removal of any trees within the Town right-of-way.
5. Applicant is required to post the "House Number" to which this driveway serves and it must be displayed in a prominent location so to be seen at night by "Emergency Vehicles" and must be installed prior to final approvals.
6. If an applicant is proposing a driveway on to a private right-of-way the applicant must provide the Town with documented proof that the property has rights to use such right-of-way.
7. Permit valid for one year from date of issue.

Signature \_\_\_\_\_ Date \_\_\_\_\_  
(Owner, Applicant or Authorized Agent)

Printed Name \_\_\_\_\_  
\_\_\_\_\_  
(FOR OFFICE USE ONLY)

Permit Issued By \_\_\_\_\_ Date \_\_\_\_\_

**ADDITIONAL NOTES and/or REQUIREMENTS**  
\_\_\_\_\_  
\_\_\_\_\_  
\_\_\_\_\_

Approved By \_\_\_\_\_ Date \_\_\_\_\_